

रोल नं.

--	--	--	--	--	--	--	--

Roll No.

परीक्षार्थी कोड को उत्तर-पुस्तिका के मुख-पृष्ठ पर अवश्य लिखें ।

Candidates must write the Code on the title page of the answer-book.

- कृपया जाँच कर लें कि इस प्रश्न-पत्र में मुद्रित पृष्ठ 12 हैं ।
- प्रश्न-पत्र में दाहिने हाथ की ओर दिए गए कोड नम्बर को छात्र उत्तर-पुस्तिका के मुख-पृष्ठ पर लिखें ।
- कृपया जाँच कर लें कि इस प्रश्न-पत्र में 26 प्रश्न हैं ।
- कृपया प्रश्न का उत्तर लिखना शुरू करने से पहले, प्रश्न का क्रमांक अवश्य लिखें ।
- इस प्रश्न-पत्र को पढ़ने के लिए 15 मिनट का समय दिया गया है । प्रश्न-पत्र का वितरण पूर्वाह्न में 10.15 बजे किया जायेगा । 10.15 बजे से 10.30 बजे तक छात्र केवल प्रश्न-पत्र को पढ़ेंगे और इस अवधि के दौरान वे उत्तर-पुस्तिका पर कोई उत्तर नहीं लिखेंगे ।
- Please check that this question paper contains 12 printed pages.
- Code number given on the right hand side of the question paper should be written on the title page of the answer-book by the candidate.
- Please check that this question paper contains 26 questions.
- **Please write down the Serial Number of the question before attempting it.**
- 15 minutes time has been allotted to read this question paper. The question paper will be distributed at 10.15 a.m. From 10.15 a.m. to 10.30 a.m., the students will read the question paper only and will not write any answer on the answer-book during this period.

भौतिक विज्ञान (सैद्धांतिक)

PHYSICS (Theory)

निर्धारित समय : 3 घंटे]

[अधिकतम अंक : 70

Time allowed : 3 hours]

[Maximum Marks : 70

सामान्य निर्देश :

- (i) सभी प्रश्न अनिवार्य हैं । इस प्रश्न-पत्र में कुल 26 प्रश्न हैं ।
- (ii) इस प्रश्न-पत्र के 5 भाग हैं : खण्ड-अ, खण्ड-ब, खण्ड-स, खण्ड-द और खण्ड-य ।
- (iii) खण्ड-अ में 5 प्रश्न हैं, प्रत्येक का 1 अंक है । खण्ड-ब में 5 प्रश्न हैं, प्रत्येक के 2 अंक हैं । खण्ड-स में 12 प्रश्न हैं, प्रत्येक के 3 अंक हैं । खण्ड-द में 4 अंक का एक मूल्याधारित प्रश्न है और खण्ड-य में 3 प्रश्न हैं, प्रत्येक के 5 अंक हैं ।
- (iv) प्रश्न-पत्र में समग्र पर कोई विकल्प नहीं है । तथापि, दो अंकों वाले एक प्रश्न में, तीन अंकों वाले एक प्रश्न में और पाँच अंकों वाले तीनों प्रश्नों में आन्तरिक चयन प्रदान किया गया है । ऐसे प्रश्नों में आपको दिए गए चयन में से केवल एक प्रश्न ही करना है ।

(v) जहाँ आवश्यक हो आप निम्नलिखित भौतिक नियतांकों के मानों का उपयोग कर सकते हैं :

$$c = 3 \times 10^8 \text{ m/s}$$

$$h = 6.63 \times 10^{-34} \text{ Js}$$

$$e = 1.6 \times 10^{-19} \text{ C}$$

$$\mu_0 = 4\pi \times 10^{-7} \text{ T m A}^{-1}$$

$$\epsilon_0 = 8.854 \times 10^{-12} \text{ C}^2 \text{ N}^{-1} \text{ m}^{-2}$$

$$\frac{1}{4\pi\epsilon_0} = 9 \times 10^9 \text{ N m}^2 \text{ C}^{-2}$$

$$m_e = 9.1 \times 10^{-31} \text{ kg}$$

$$\text{न्यूट्रॉन का द्रव्यमान} = 1.675 \times 10^{-27} \text{ kg}$$

$$\text{प्रोटॉन का द्रव्यमान} = 1.673 \times 10^{-27} \text{ kg}$$

$$\text{आवोगाद्रो संख्या} = 6.023 \times 10^{23} \text{ प्रति ग्राम मोल}$$

$$\text{बोल्ट्ज़मान नियतांक} = 1.38 \times 10^{-23} \text{ JK}^{-1}$$

General Instructions :

- (i) *All questions are compulsory. There are 26 questions in all.*
- (ii) *This question paper has five sections : Section A, Section B, Section C, Section D and Section E.*
- (iii) *Section A contains five questions of one mark each, Section B contains five questions of two marks each, Section C contains twelve questions of three marks each, Section D contains one value based question of four marks and Section E contains three questions of five marks each.*
- (iv) *There is no overall choice. However, an internal choice has been provided in one question of two marks, one question of three marks and all the three questions of five marks weightage. You have to attempt only one of the choices in such questions.*
- (v) *You may use the following values of physical constants wherever necessary :*

$$c = 3 \times 10^8 \text{ m/s}$$

$$h = 6.63 \times 10^{-34} \text{ Js}$$

$$e = 1.6 \times 10^{-19} \text{ C}$$

$$\mu_0 = 4\pi \times 10^{-7} \text{ T m A}^{-1}$$

$$\epsilon_0 = 8.854 \times 10^{-12} \text{ C}^2 \text{ N}^{-1} \text{ m}^{-2}$$

$$\frac{1}{4\pi\epsilon_0} = 9 \times 10^9 \text{ N m}^2 \text{ C}^{-2}$$

$$m_e = 9.1 \times 10^{-31} \text{ kg}$$

$$\text{mass of neutron} = 1.675 \times 10^{-27} \text{ kg}$$

$$\text{mass of proton} = 1.673 \times 10^{-27} \text{ kg}$$

$$\text{Avogadro's number} = 6.023 \times 10^{23} \text{ per gram mole}$$

$$\text{Boltzmann constant} = 1.38 \times 10^{-23} \text{ JK}^{-1}$$



खण्ड – अ

Section – A

1. NAND गेट का तर्क प्रतीक खींचिए और इसकी सत्यमान सारणी दीजिए ।
Draw the logic symbol of NAND gate and give its Truth Table. 1
2. AC स्रोत की आवृत्ति में परिवर्तन के साथ संधारित्र प्रतिघात में विचरण को दर्शाने के लिए ग्राफ खींचिए ।
Plot a graph showing variation of capacitive reactance with the change in the frequency of the AC source. 1
3. आयाम मॉड्यूलन और आवृत्ति मॉड्यूलन के बीच विभेदन कीजिए ।
Distinguish between amplitude modulation and frequency modulation. 1
4. किसी चालक के समविभव पृष्ठ के किसी बिन्दु पर विद्युत क्षेत्र रेखाएँ पृष्ठ के लम्बवत क्यों होती हैं ?
Why are electric field lines perpendicular at a point on an equipotential surface of a conductor ? 1
5. किसी संधारित्र को किसी परिवर्ती आवृत्ति के AC स्रोत से संयोजित किया गया है । यदि AC स्रोत की आवृत्ति घटा दी जाए, तो क्या विस्थापन धारा परिवर्तित हो जाएगी ?
A variable frequency AC source is connected to a capacitor. Will the displacement current change if the frequency of the AC source is decreased ? 1

खण्ड – ब

Section – B

6. 20 cm भुजा वाले किसी वर्गाकार लूप जिससे 1A धारा प्रवाहित हो रही है, को किसी अनन्त लम्बाई के सीधे तार जिससे 2A धारा प्रवाहित हो रही है के निकट चित्र में दर्शाए अनुसार समान तल में रखा गया है । 2

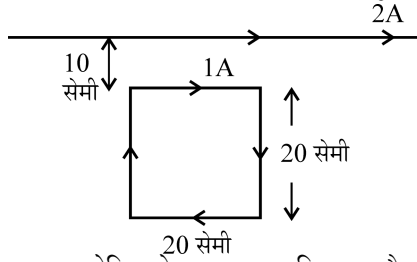

धारावाही चालक के कारण लूप पर आरोपित नेट बल का परिमाण और दिशा परिकलित कीजिए ।

अथवा

200 फेरों और 100 cm^2 क्षेत्रफल की किसी वर्गाकार समतल कुण्डली से 5A अपरिवर्ती धारा प्रवाहित हो रही है । यह कुण्डली 0.2 T के ऐसे एकसमान चुम्बकीय क्षेत्र में स्थित है, जिसकी दिशा कुण्डली के तल के लम्बवत है । जब इस कुण्डली का तल चुम्बकीय क्षेत्र से 60° का कोण बनाता है तब उस स्थिति में कुण्डली पर लगा बल-आघूर्ण परिकलित कीजिए । किस विन्यास में यह कुण्डली स्थायी साम्यावस्था में होगी ?

A square loop of side 20 cm carrying current of 1A is kept near an infinite long straight wire carrying a current of 2A in the same plane as shown in the figure.

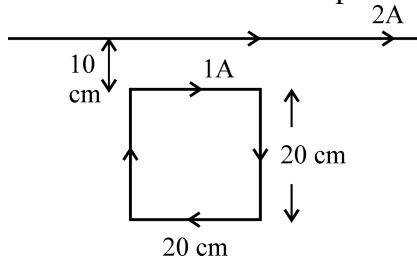

Calculate the magnitude and direction of the net force exerted on the loop due to the current carrying conductor.

OR

A square shaped plane coil of area 100 cm^2 of 200 turns carries a steady current of 5A. It is placed in a uniform magnetic field of 0.2 T acting perpendicular to the plane of the coil. Calculate the torque on the coil when its plane makes an angle of 60° with the direction of the field. In which orientation will the coil be in stable equilibrium ?

7. उन वैद्युत चुम्बकीय विकिरणों का नाम लिखिए (i) जिनका उपयोग कैंसर की कोशिकाओं को नष्ट करने में किया जाता है, (ii) जिनसे त्वचा ताम्र रंग की हो जाती है, (iii) पृथ्वी की उष्णता बनाए रखते हैं । 2
इनमें से किसी एक प्रकार की तरंगों को उत्पन्न करने की विधि का संक्षेप में वर्णन कीजिए ।

Name the types of e.m. radiations which (i) are used in destroying cancer cells, (ii) cause tanning of the skin and (iii) maintain the earth's warmth.

Write briefly a method of producing any one of these waves.

8. चित्र में हाइड्रोजन परमाणु का ऊर्जा स्तर आरेख दर्शाया गया है : 2
(a) वह संक्रमण ज्ञात कीजिए जिसमें 496 nm तरंगदैर्घ्य के फोटॉन का उत्सर्जन होता है ।

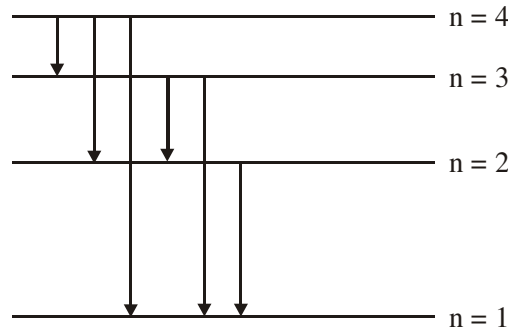

- (b) किस संक्रमण के संगत अधिकतम तरंगदैर्घ्य के विकिरण उत्सर्जित होते हैं ? अपने उत्तर की पुष्टि कीजिए ।

The figure shows energy level diagram of hydrogen atom.

- (a) Find out the transition which results in the emission of a photon of wavelength 496 nm .

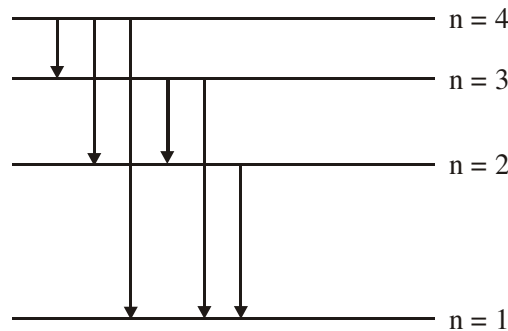

- (b) Which transition corresponds to the emission of radiation of maximum wavelength ? Justify your answer.

9. 'विद्युत फ्लक्स' की परिभाषा और इसका SI मात्रक लिखिए । विद्युत क्षेत्र $\vec{E} = 3 \times 10^3 \hat{i}$ N/C के कारण किसी 10 cm भुजा वाले वर्ग से गुजरने वाला फ्लक्स कितना है, जबकि इसे \vec{E} के अभिलम्बवत् रखा गया है । 2
 Define the term 'electric flux'. Write its SI units. What is the flux due to electric field $\vec{E} = 3 \times 10^3 \hat{i}$ N/C through a square of side 10 cm, when it is held normal to \vec{E} ?

10. चित्र में दर्शाए गए प्रतिरोधकों के नेटवर्क द्वारा बैटरी से ली गयी धारा परिकलित कीजिए । 2

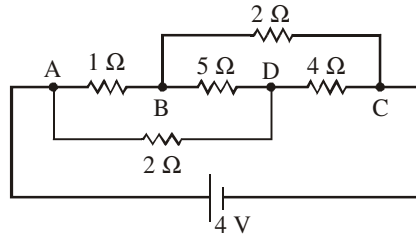

Calculate the current drawn from the battery by the network of resistors shown in the figure.

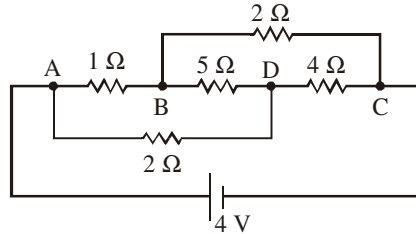

खण्ड – स

Section – C

11. (a) साधारण रंगीन काँच के चश्मों की तुलना में अच्छी गुणता के पोलरॉयडों के बने चश्मों को प्रायिकता क्यों दी जाती है ? कारण देकर स्पष्ट कीजिए । 3
- (b) दो पोलरॉयडों P_1 तथा P_2 को क्रॉसित स्थितियों में रखा गया है । P_1 और P_2 के बीच कोई तीसरा पोलरॉयड P_3 इस प्रकार रखा जाता है कि P_3 का पारित अक्ष P_1 के समान्तर है । P_2 से पारगमित प्रकाश की तीव्रता (I_2) P_3 को घूर्णन कराने पर किस प्रकार परिवर्तन होगी ? P_1 और P_3 के परित अक्षों के बीच कोण ' θ ' और तीव्रता ' I_2 ' के बीच ग्राफ खींचिए ।
- (a) Good quality sun-glasses made of polaroids are preferred over ordinary coloured glasses. Justifying your answer.
- (b) Two polaroids P_1 and P_2 are placed in crossed positions. A third polaroid P_3 is kept between P_1 and P_2 such that pass axis of P_3 is parallel to that of P_1 . How would the intensity of light (I_2) transmitted through P_2 vary as P_3 is rotated ? Draw a plot of intensity ' I_2 ' Vs the angle ' θ ', between pass axes of P_1 and P_3 .

12. (a) नीचे दी गयी नाभिकीय अभिक्रियाओं को पूरा कीजिए : 3
- (i) ${}_{84}^{208}\text{Po} \rightarrow {}_{82}^{204}\text{Pb} + \dots$
- (ii) ${}_{15}^{32}\text{P} \rightarrow {}_{16}^{32}\text{S} + \dots$
- (b) (i) β^- और (ii) β^+ क्षय के लिए उत्तरदायी नाभिक में अन्तर्ग्रस्त मूल प्रक्रिया लिखिए ।
- (c) न्यूट्रिनो का प्रायोगिक संसूचन कठिन क्यों पाया गया ?
- (a) Complete the following nuclear reactions :
- (i) ${}_{84}^{208}\text{Po} \rightarrow {}_{82}^{204}\text{Pb} + \dots$
- (ii) ${}_{15}^{32}\text{P} \rightarrow {}_{16}^{32}\text{S} + \dots$
- (b) Write the basic process involved in nuclei responsible for (i) β^- and (ii) β^+ decay.
- (c) Why is it found experimentally difficult to detect neutrinos ?
13. ताप $T > 0\text{K}$ पर (i) n-प्रकार और (ii) p-प्रकार के अर्धचालकों के ऊर्जा-बैंड आरेख खींचिए । 3
- n-प्रकार के प्रकरण में Si-अर्धचालकों के ऊर्जा-बैंड आरेख में दाता ऊर्जा स्तर चालक बैंड की तली के कुछ नीचे तथा p-प्रकार के अर्धचालकों में ग्राही ऊर्जा स्तर संयोजी बैंड के शीर्ष से कुछ ऊपर होता है । स्पष्ट कीजिए कि चालक और संयोजी बैंडों में इन ऊर्जा-स्तरों की क्या भूमिका होती है ।
- Draw the energy band diagrams of (i) n-type and (ii) p-type semiconductor at temperature, $T > 0\text{K}$.
- In the case n-type Si semiconductor, the donor energy level is slightly below the bottom of conduction band whereas in p-type semiconductor the acceptor energy level is slightly above the top of the valence band. Explain, what role do these energy levels play in conduction and valence bands.
14. अंतरण अभिलक्षण (V_0 और V_i के बीच) का ग्राफ खींचिए और दर्शाइए कि इस अभिलक्षण का कौन सा भाग प्रवर्धन के लिए उपयोग किया जाता है और क्यों ? 3
- किसी आधार बायसित ट्रांजिस्टर प्रवर्धक का CE विन्यास में परिपथ आरेख खींचिए और संक्षेप में इसकी कार्यविधि की व्याख्या कीजिए ।
- Draw a plot of transfer characteristic (V_0 vs V_i) and show which portion of the characteristic is used in amplification and why ?
- Draw the circuit diagram of base bias transistor amplifier in CE configuration and briefly explain its working.
15. इन्टरनेट के उपयोग में नीचे दिए गए पदों की व्याख्या कीजिए : 3
- (i) इन्टरनेट सर्फिंग
- (ii) सोशल नेटवर्किंग
- (iii) ई-मेल
- Explain the following terms in relation to the use of internet :
- (i) Internet surfing
- (ii) Social networking
- (iii) E-mail

16. (a) किसी चालक में प्रवाहित धारा 'I' और इलेक्ट्रॉन के अपवाह वेग \vec{v}_d के बीच संबंध व्युत्पन्न कीजिए । 3
 (b) चित्र में किसी तार की अनुप्रस्थ काट से प्रवाहित धारा 'I' और समय 't' के बीच ग्राफ दर्शाया गया है । इस ग्राफ का उपयोग करके तार से 10s में प्रवाहित आवेश ज्ञात कीजिए ।

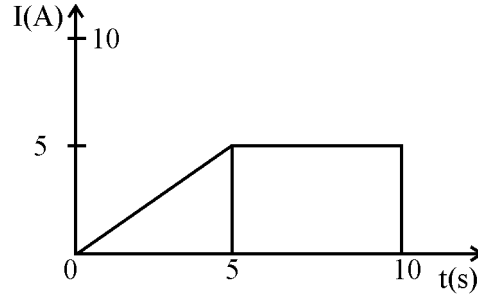

- (a) Deduce the relation between current I flowing through a conductor and drift velocity \vec{v}_d of the electrons.
 (b) Figure shows a plot of current 'I' flowing through the cross-section of a wire versus the time 't'. Use the plot to find the charge flowing in 10s through the wire.

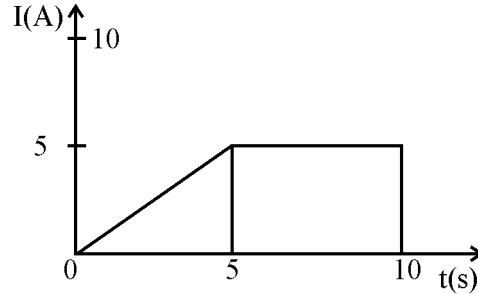

17. किसी पोटेंशियोमीटर का परिपथ आरेख खींचकर इसका कार्यकारी सिद्धान्त लिखिए । दो सेलों की emf की तुलना करने में इसका उपयोग किस प्रकार किया जाता है इसका वर्णन करने वाला आवश्यक सूत्र व्युत्पन्न कीजिए । 3

अथवा

परिपथ आरेख की सहायता से मीटर सेतु के कार्यकारी सिद्धान्त की व्याख्या कीजिए । इसका उपयोग किसी दिए गए तार का अज्ञात प्रतिरोध निर्धारित करने में किस प्रकार किया जाता है ? परिणाम में न्यूनतम त्रुटि के लिए बरती जाने वाली आवश्यक सावधानियाँ लिखिए ।

Draw a circuit diagram of a potentiometer. State its working principle. Derive the necessary formula to describe how it is used to compare the emfs of the two cells.

OR

With the help of the circuit diagram, explain the working principle of meter bridge. How is it used to determine the unknown resistance of a given wire ? Write the necessary precautions to minimize the error in the result.

18. (a) किसी चल कुण्डली गैल्वेनोमीटर में चुम्बकीय क्षेत्र त्रिज्य (अरीय) क्यों बनाया जाता है ? समझाइए यह किस प्रकार बनाया जाता है । 3
 (b) किसी गैल्वेनोमीटर जिसका प्रतिरोध 'G' है, को इसके श्रेणी में कोई प्रतिरोध 'R' संयोजित करके (0-V) वोल्ट परिसर के वोल्टमीटर में परिवर्तित किया जा सकता है । यदि इसे 0 से V/2 परिसर के वोल्टमीटर में परिवर्तित करना हो, तो कितने प्रतिरोध की आवश्यकता होगी ?

- (a) Why is the magnetic field radial in a moving coil galvanometer ? Explain how it is achieved.
- (b) A galvanometer of resistance 'G' can be converted into a voltmeter of range (0-V) volts by connecting a resistance 'R' in series with it. How much resistance will be required to change its range from 0 to V/2 ?
19. किसी ac वोल्टता $V = V_0 \sin \omega t$ के स्रोत को प्रतिरोध 'R' और संधारित्र 'C' के श्रेणी संयोजन से जोड़ा गया है। इसके लिए फेज़र आरेख खींचिए और इसका उपयोग (i) परिपथ की प्रतिबाधा और (ii) कला-कोण के लिए व्यंजक प्राप्त करने में कीजिए। 3
- A source of ac voltage $V = V_0 \sin \omega t$ is connected to a series combination of a resistor 'R' and a capacitor 'C'. Draw the phasor diagram and use it to obtain the expression for (i) impedance of the circuit and (ii) phase angle.
20. अनुप्रस्थ काट-क्षेत्रफल $1.6 \times 10^{-4} \text{m}^2$ और कसकर पास-पास लपेटे गए 2000 फेरों की परिनालिका जिससे 4.0 A धारा प्रवाहित हो रही है इसके केन्द्र से होकर निलम्बित है और यह क्षैतिज तल में घूम सकती है। (i) इस परिनालिका से संबद्ध चुम्बकीय आघूर्ण, (ii) यदि परिनालिका के अक्ष से 30° कोण पर कोई $7.5 \times 10^{-2} \text{T}$ का क्षैतिज चुम्बकीय क्षेत्र व्यवस्थित किया गया है, तो परिनालिका पर लगे बल-आघूर्ण का परिमाण और दिशा ज्ञात कीजिए। 3
- A closely wound solenoid of 2000 turns and cross sectional area $1.6 \times 10^{-4} \text{m}^2$ carrying a current of 4.0 A is suspended through its centre allowing it to turn in a horizontal plane. Find (i) the magnetic moment associated with the solenoid, (ii) magnitude and direction of the torque on the solenoid if a horizontal magnetic field of $7.5 \times 10^{-2} \text{T}$ is set up at an angle of 30° with the axis of the solenoid.
21. (a) यंग के द्विझिरी प्रयोग में दो झिरियों की मोटाई का अनुपात 4:1 है। व्यतिकरण पैटर्न में उच्चिष्ठ और निम्निष्ठ की तीव्रताओं के अनुपात का मूल्यांकन कीजिए। 3
- (b) क्या व्यतिकरण पैटर्न ने चमकीली और काली फ्रिन्जे दिखाई देना, किसी भी रूप में, ऊर्जा संरक्षण नियम का उल्लंघन है? व्याख्या कीजिए।
- (a) The ratio of the widths of two slits in Young's double slit experiment is 4 : 1. Evaluate the ratio of intensities at maxima and minima in the interference pattern.
- (b) Does the appearance of bright and dark fringes in the interference pattern violate, in any way, conservation of energy ? Explain.
22. (a) उन कारकों को लिखिए जिनके द्वारा किसी दूरदर्शक की विभेदन क्षमता में वृद्धि की जा सकती है। 3
- (b) 1 mm चौड़ाई की एकल झिरी पर जब झिरी के अभिलम्बवत 600 nm तरंगदैर्घ्य का प्रकाश आपतन करता है, तो इसके कारण प्राप्त विवर्तन पैटर्न के प्रथम कोटि उच्चिष्ठ और तृतीय कोटि निम्निष्ठ के बीच कोणीय पृथक्करण का आकलन कीजिए।
- (a) Write the factors by which the resolving power of a telescope can be increased.
- (b) Estimate the angular separation between first order maximum and third order minimum of the diffraction pattern due to a single slit of width 1 mm, when light of wavelength 600 nm is incident normal on it.



खण्ड – द

Section – D

23. विद्यालय की छुट्टी के तुरन्त बाद जैसे ही बिमला अपनी सहेलियों के साथ बाहर निकली उसने देखा कि अचानक बादलों की गर्जन के साथ बिजली चमकने लगी है। उन्हें शरण के लिए कोई उपयुक्त स्थान नहीं मिल पाया। डॉ. कपूर जो वहीं से अपनी कार से गुजर रहे थे उन्होंने इन बच्चों को देखा और उन्हें अपनी कार में बैठने का प्रस्ताव दिया, यही नहीं उन्होंने इन बच्चों को इनके घरों के निकट की बस्ती में छोड़ा। बिमला के माता-पिता जो बिमला का इन्तजार कर रहे थे, यह देखा और उन्होंने डॉ. कपूर का आभार व्यक्त किया।

4

- (1) डॉ. कपूर और बिमला के माता-पिता द्वारा किन मूल्यों को दर्शाया गया ?
- (2) विशेषकर तड़ित और गर्जन के समय कार के भीतर होना सुरक्षित क्यों माना जाता है ?
- (3) “परावैद्युत सामर्थ्य” पद की परिभाषा लिखिए। यह क्या सूचित करती है ?

Immediately after school hour, as Bimla with her friends came out, they noticed that there was a sudden thunderstorm accompanied by the lightening. They could not find any suitable place for shelter. Dr. Kapoor who was passing thereby in his car noticed these children and offered them to come in their car. He even took care to drop them to the locality where they were staying. Bimla's parents, who were waiting, saw this and expressed their gratitude to Dr. Kapoor.

- (1) What values did Dr. Kapoor and Bimla's parents displayed ?
- (2) Why is it considered safe to be inside a car especially during lightening and thunderstorm ?
- (3) Define the term 'dielectric strength'. What does this term signify ?

खण्ड – य

Section – E

24. (a) प्रकाश-विद्युत प्रभाव के उन तीन प्रेक्षित अभिलक्षणों को लिखिए जिनकी व्याख्या प्रकाश के तरंग सिद्धान्त द्वारा नहीं की जा सकती।
स्पष्ट कीजिए कि आइंस्टीन के प्रकाश-विद्युत समीकरण का उपयोग इनका संतोषजनक वर्णन करने के लिए किस प्रकार किया जाता है।

5

- (b) चित्र में दो प्रकाश-सुग्राही पदार्थों M_1 तथा M_2 के लिए आपतित विकिरणों की आवृत्ति (ν) और निरोधी विभव (V_0) के बीच ग्राफ दर्शाया गया है। स्पष्ट कीजिए कि
- (i) दोनों रेखाओं का ढलान समान क्यों है ?
 - (ii) आपतित विकिरणों की समान आवृत्ति के लिए किस पदार्थ से उत्सर्जित इलेक्ट्रॉनों की गतिज ऊर्जा अधिक है ?

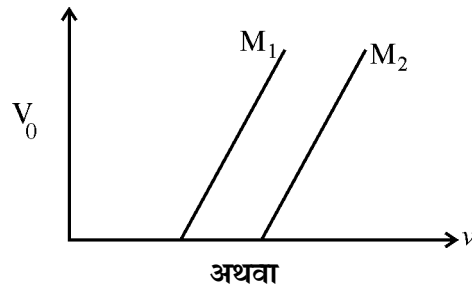

- (a) रदरफोर्ड के प्रकीर्णन प्रयोग में लक्ष्य-नाभिक के कूलॉमी क्षेत्र में α -कणों द्वारा अनुरेखित प्रक्षेप-पथ खींचिए और स्पष्ट कीजिए कि किस प्रकार इसके द्वारा नाभिक के साइज़ का अनुमान लगाया गया ।
- (b) संक्षेप में वर्णन कीजिए कि गतिमान इलेक्ट्रॉनों की तरंग प्रकृति प्रायोगिक रूप से किस प्रकार प्रमाणित की गयी ।
- (c) जब ड्यूटेरॉनों और α -कणों को उनकी विराम अवस्थाओं से समान त्वरित विभव, V के द्वारा त्वरित किया जाता है, तो इनसे संबद्ध दे ब्राग्ली तरंगदैर्घ्यों के अनुपात का आकलन कीजिए ।
- (a) Write three observed features of photoelectric effect which cannot be explained by wave theory of light.

Explain how Einstein's photoelectric equation is used to describe these features satisfactorily.

- (b) Figure shows a plot of stopping potential (V_0) with frequency (ν) of incident radiation for two photosensitive materials M_1 and M_2 . Explain

- (i) why the slope of both the lines is same ?
- (ii) for which material emitted electrons have greater kinetic energy for the same frequency of incident radiation ?

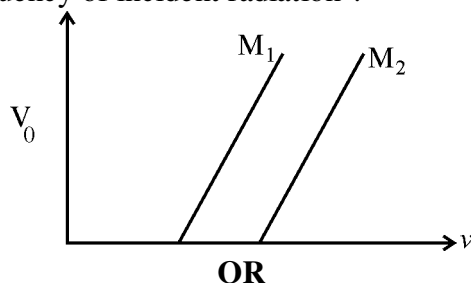

OR

- (a) In Rutherford scattering experiment, draw the trajectory traced by α -particles in the coulomb field of target nucleus and explain how this led to estimate the size of the nucleus.
- (b) Describe briefly how wave nature of moving electrons was established experimentally.
- (c) Estimate the ratio of de-Broglie wavelengths associated with deuterons and α -particles when they are accelerated from rest through the same accelerating potential V .

25. (a) लेंज का नियम लिखिए । नीचे दी गयी स्थिति में संधारित्र की ध्रुवणता का अनुमान लगाने में इस नियम का उपयोग कीजिए ।

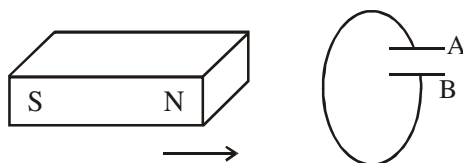

- (b) कोई जेटयान 1800 km/h की चाल से पश्चिम दिशा में गमन कर रहा है ।
- (i) यदि जिस जगह वह गमन कर रहा है वहाँ पृथ्वी के चुम्बकीय क्षेत्र का परिमाण $5 \times 10^{-4} \text{ T}$ और नति कोण 30° है, तो 25 m विस्तार की जेटयान की पंखुड़ियों के दो सिरों के बीच उत्पन्न वोल्टता-अन्तर का अनुमान लगाइए ।
- (ii) यदि जेटयान की दिशा पश्चिम से उत्तर की ओर हो जाए, तो उत्पन्न वोल्टता पर क्या प्रभाव पड़ेगा ?

अथवा

कुण्डलियों के युगल के अन्योन्य प्रेरकत्व की परिभाषा लिखिए और जिन कारकों पर यह निर्भर करता है उनका उल्लेख कीजिए ।

चित्र में दर्शाए अनुसार 20 cm भुजा का कोई वर्ग-लूप 0.1 T के एकसमान चुम्बकीय क्षेत्र के प्रभाव क्षेत्र से प्रारम्भ में 30 cm दूरी पर है । इसके पश्चात इसे दायीं ओर 10 cm s^{-1} के वेग से उस समय तक गमन कराया जाता है, जब तक कि यह इस क्षेत्र के प्रभाव क्षेत्र से बाहर नहीं निकल जाता ।

नीचे दिए गए विचरणों को दर्शाने के लिए ग्राफ खींचिए :

- समय (t) के साथ लूप से गुजरने वाले चुम्बकीय फ्लक्स (ϕ) का विचरण
- समय (t) के साथ लूप में प्रेरित emf (ϵ)
- यदि लूप का प्रतिरोध 0.1Ω है, तो लूप में प्रेरित धारा में विचरण

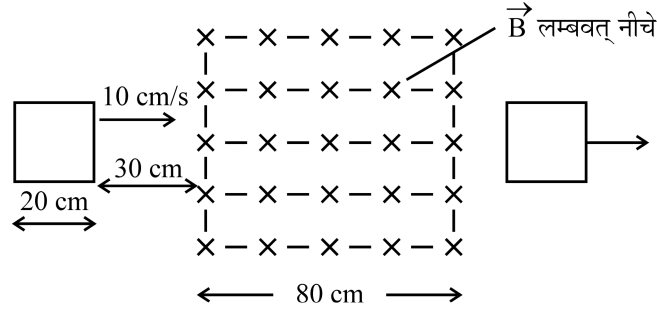

- (a) State Lenz's law. Use it to predict the polarity of the capacitor in the situation given below :

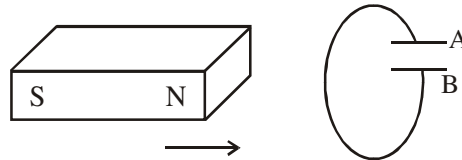

- (b) A jet plane is travelling towards west at a speed of 1800 km/h.
- Estimate voltage difference developed between the ends of the wing having a span of 25 m if the Earth's magnetic field at the location has a magnitude of $5 \times 10^{-4} \text{ T}$ and dip angle is 30° .
 - How will the voltage developed be affected if the jet changes its direction from west to north ?

OR

Define mutual inductance of a pair of coils and write on which factors does it depend.

A square loop of side 20 cm is initially kept 30 cm away from a region of uniform magnetic field of 0.1 T as shown in the figure. It is then moved towards the right with a velocity of 10 cm s^{-1} till it goes out of the field.

Plot a graph showing the variation of

- magnetic flux (ϕ) through the loop with time (t).
- induced emf (ϵ) in the loop with time t.
- induced current in the loop if it has resistance of 0.1Ω .

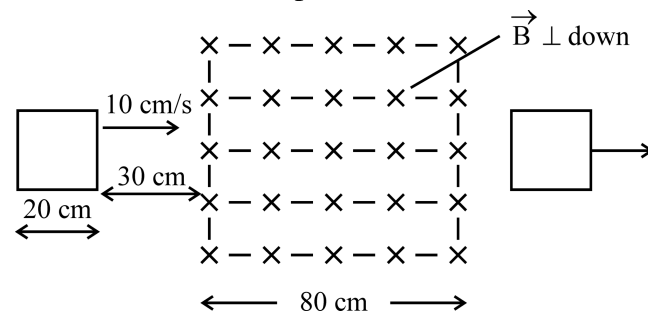

26. (a) तरंगगात्र की परिभाषा लिखिए । यह किरण से किस प्रकार भिन्न है ?
 (b) नीचे दिए गए प्रत्येक प्रकरण के लिए तरंगगात्र की आकृति दर्शाइए ।
 (i) किसी बिन्दु स्रोत से प्रकाश का अपसारित होना ।
 (ii) जब बिन्दु स्रोत किसी उत्तल लेंस के फोकस पर है, तब लेंस से प्रकाश निर्गत होते हुए
 (iii) हाइगोन्स के द्वितीयक तरंगिका के निर्माण का उपयोग करते हुए, सघन माध्यम से विरल माध्यम में किसी समतल तरंगगात्र के गमन को दर्शाने के लिए आरेख खींचिए ।

अथवा

- (a) किसी संयुक्त सूक्ष्मदर्शी द्वारा प्रतिबिम्ब बनना दर्शाने के लिए किरण आरेख खींचिए । उस स्थिति में कुल आवर्धन के लिए व्यंजक प्राप्त कीजिए जब प्रतिबिम्ब अनन्त पर बनता है ।
 (b) किसी संयुक्त सूक्ष्मदर्शी की विभेदन क्षमता किस प्रकार प्रभावित होती है, जब
 (i) अभिदृश्यक की फोकस दूरी घट जाती है ।
 (ii) प्रकाश की तरंगदैर्घ्य अधिक हो जाती है ?
 अपने उत्तर की पुष्टि कारण सहित कीजिए ।
 (a) Define a wavefront. How is it different from a ray ?
 (b) Depict the shape of a wavefront in each of the following cases.
 (i) Light diverging from point source.
 (ii) Light emerging out of a convex lens when a point source is placed at its focus.
 (iii) Using Huygen's construction of secondary wavelets, draw a diagram showing the passage of a plane wavefront from a denser into a rarer medium.

OR

- (a) Draw a ray diagram showing the image formation by a compound microscope. Obtain expression for total magnification when the image is formed at infinity.
 (b) How does the resolving power of a compound microscope get affected, when
 (i) focal length of the objective is decreased.
 (ii) the wavelength of light is increased ?
 Give reasons to justify your answer.

MARKING SCHEME
SET 55/1(Compartment)

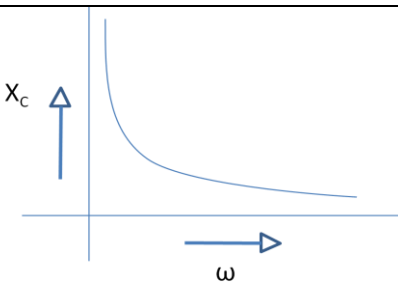
Q. No.	Expected Answer / Value Points	Marks	Total Marks															
Section A																		
Set1,Q1 Set2,Q5 Set3,Q4	If it were not so, the presence of a component of the field along the surface would violate its equipotential nature. [Accept any other correct explanation]	1	1															
Set1,Q2 Set2,Q1 Set3,Q5	It would decrease. [NOTE: Also accept if the student just writes 'yes']	1	1															
Set1,Q3 Set2,Q2 Set3,Q1	 <table border="1" style="display: inline-table; margin-left: 20px;"> <thead> <tr> <th>A</th> <th>B</th> <th>Y</th> </tr> </thead> <tbody> <tr> <td>0</td> <td>0</td> <td>1</td> </tr> <tr> <td>0</td> <td>1</td> <td>1</td> </tr> <tr> <td>1</td> <td>0</td> <td>1</td> </tr> <tr> <td>1</td> <td>1</td> <td>0</td> </tr> </tbody> </table>	A	B	Y	0	0	1	0	1	1	1	0	1	1	1	0	1/2 + 1/2	1
A	B	Y																
0	0	1																
0	1	1																
1	0	1																
1	1	0																
Set1,Q4 Set2,Q3 Set3,Q2		1	1															
Set1,Q5 Set2,Q4 Set3,Q3	In amplitude modulation, the amplitude, of the carrier wave, changes in accordance with the modulating signal, while in frequency modulation, frequency of the carrier wave varies in accordance with the modulating signal. [NOTE: Also accept if the student draws graphs for the two types of modulation]	1	1															
Section B																		
Set1,Q6 Set2,Q10 Set3,Q9	<table border="1" style="width: 100%; border-collapse: collapse;"> <tbody> <tr> <td style="padding: 5px;">Definition of electric flux</td> <td style="text-align: right; padding: 5px;">1/2</td> </tr> <tr> <td style="padding: 5px;">S.I. unit</td> <td style="text-align: right; padding: 5px;">1/2</td> </tr> <tr> <td style="padding: 5px;">Calculation of flux</td> <td style="text-align: right; padding: 5px;">1</td> </tr> </tbody> </table> <p>The 'electric flux', through an elemental area $d\vec{s}$, equals the dot product of $d\vec{s}$, with the electric field, \vec{E}. [Alternatively: Electric flux is the number of electric field lines passing through a given area.] [Also accept, $d\phi = \vec{E} \cdot d\vec{s}$ Or $\phi = \oint \vec{E} \cdot d\vec{s}$]</p> <p>S.I. units: $\left(\frac{\text{N}\cdot\text{m}^2}{\text{C}}\right)$ or (V-m)</p> <p>$\phi = \vec{E} \cdot \vec{S} = ES(\text{as } \theta = 0^\circ)$</p>	Definition of electric flux	1/2	S.I. unit	1/2	Calculation of flux	1	1/2	1/2									
Definition of electric flux	1/2																	
S.I. unit	1/2																	
Calculation of flux	1																	

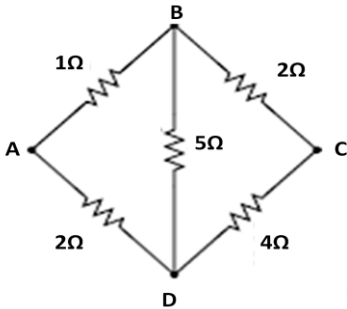
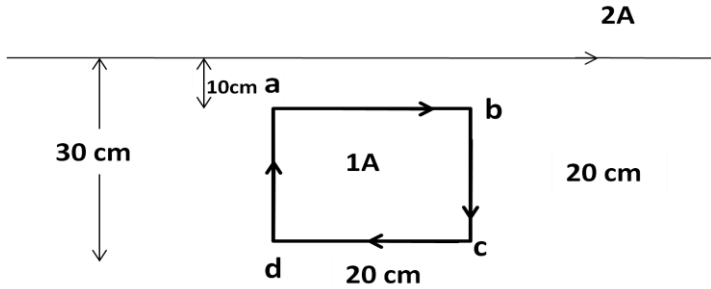

	$= 3 \times 10^3 \times (10 \times 10^{-2})^2 \frac{\text{N}\cdot\text{m}^2}{\text{C}}$ $= 30 \frac{\text{N}\cdot\text{m}^2}{\text{C}}$	1/2	2
Set1,Q7 Set2,Q6 Set3,Q10	<div style="border: 1px solid black; padding: 5px; margin-bottom: 10px;"> Calculation of Equivalent Resistance of the network 1 1/2 Calculation of current 1/2 </div> <p>The given network has the form given below:</p>  <p>It is a balanced wheatstone Bridge. Its equivalent resistance, R, is given by</p> $\frac{1}{R} = \frac{1}{1+2} + \frac{1}{2+4} = \frac{1}{2}$ $R = 2\Omega$ <p>\therefore Current drawn = $\frac{4V}{2\Omega} = 2A$</p>	1/2 1/2 1/2	2
Set1,Q8 Set2,Q7 Set3,Q6	<div style="border: 1px solid black; padding: 5px; margin-bottom: 10px;"> Formula 1/2 Calculation of net force on the loop 1 Direction of the net force 1/2 </div>  <p>Here $I_1 = 2A$; $I_2 = 1A$ $d_1 = 10\text{ cm}$; $d_2 = 30\text{ cm}$ $\mu_0 = 4\pi \times 10^{-7} \text{ Tm A}^{-1}$ We have $F = \frac{\mu_0 I_1 I_2 l}{2\pi d}$ $\therefore \text{Net force on sides ab and cd}$ $= \frac{\mu_0 2 \times 1}{2\pi} \times 20 \times 10^{-2} \left[\frac{1}{10 \times 10^{-2}} - \frac{1}{30 \times 10^{-2}} \right] \text{N}$ $= 4 \times 10^{-7} \times 20 \left[\frac{20}{10 \times 30} \right] \text{N}$ $= \frac{16}{3} \times 10^{-7} \text{N} = 5.33 \times 10^{-7} \text{N}$ <p>This net force is directed towards the infinitely long straight wire.</p> </p>	1/2 1/2	



Section C

Set1,Q11
Set2,Q19
Set3,Q16

(a) Derivation of the relation between I and $ \vec{v}_d $	2
(b) Calculation of the charge flowing in 10 s	1

(a) According to the figure,
 $\Delta x = v_d st$
Hence, amount of charge crossing area A in time Δt

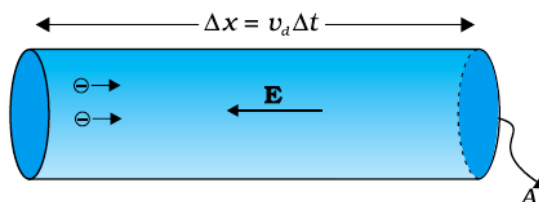

$\therefore \Delta Q = I\Delta t = neA|v_d|\Delta t$
 $\therefore I = neAv_d$

(b) Charge flowing = $\sum I\Delta t$
= area under the curve
 $= \left[\frac{1}{2} \times 5 \times 5 + 5(10 - 5) \right] C$
 $= 37.5 C$

1/2

1/2

1/2

1/2

1/2

1/2

3

Set1,Q12
Set2,Q20
Set3,Q17

Circuit Diagram	1
Working Principle	1/2
Derivation of necessary formula	1 1/2

The circuit diagram , of the potentiometer, is as shown here:

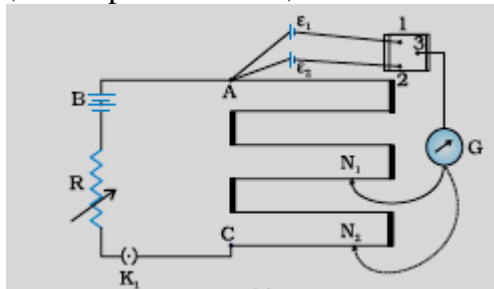

Working Principle:

The potential drop, V , across a length l of a uniform wire, is proportional to the length l of the wire.

(or $V \propto l$ (for a uniform wire))

Derivation:

Let the points 1 and 3 be connected together. Let the balance point be at the point N_1 where $AN_1=l_1$

Next let the points 2 and 3 be connected together. Let the balance point be at the point N_2 where $AN_2=l_2$.

We then have

$\varepsilon_1 = kl_1$

and $\varepsilon_2 = kl_2$

1

1/2

1/2

1/2

$$\therefore \frac{\varepsilon_1}{\varepsilon_2} = \frac{l_1}{l_2}$$

OR

Circuit Diagram	1/2
Working Principle	1
Determination of unknown resistance	1
Precautions	1/2

The circuit diagram of the meter bridge is as shown below:

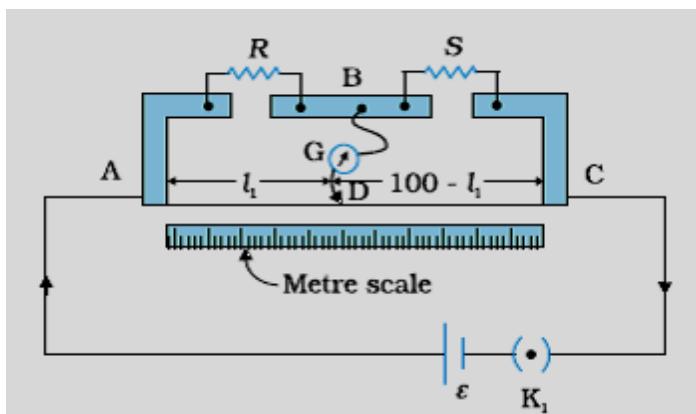

Working Principle: The working principle of the meter bridge is the same as that of a wheatstone bridge. The Wheatstone bridge gets balanced when:

$$\frac{R_2}{R_1} = \frac{R_4}{R_3}$$

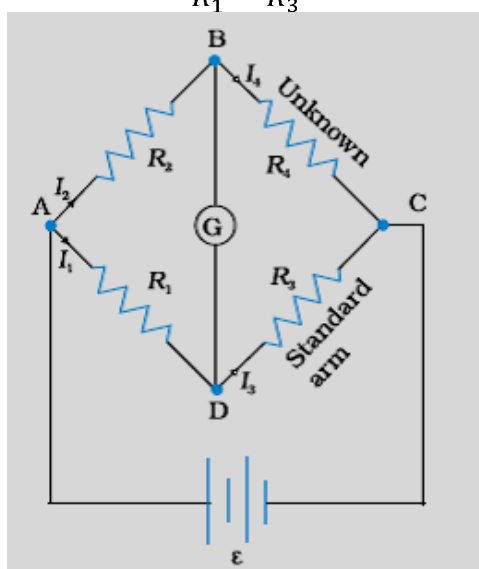

For the meter bridge, circuit shown above, this relation takes the form

$$\frac{R}{S} = \frac{l_1}{(100 - l_1)}$$

Determination of unknown Resistance (R):

In the circuit diagram shown above, S is taken as a known standard resistance. We find the value of the balancing length l_1 , corresponding to a given value of S . We then use the relation:

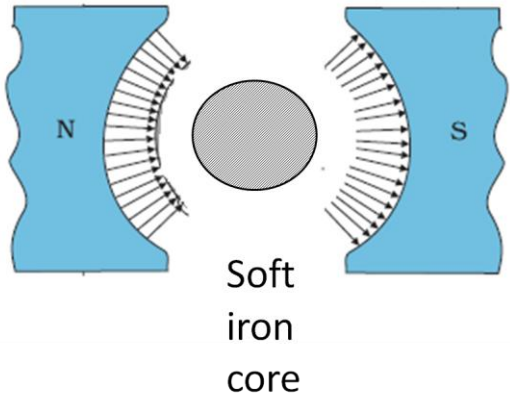
	$\frac{R}{S} = \frac{l_1}{(100 - l_1)}$ <p>to calculate R. By choosing (at least three) different value of S, we calculate R each time. The average of these values of R gives the value of the unknown resistance.</p> <p>Precautions: (1) Make all contacts in a neat, clean and tight manner (2) Select those values of S for which the balancing length is close to the middle point of the wire. [Any one]</p>	1/2 1/2	3								
Set1,Q13 Set2,Q21 Set3,Q18	<table border="1" data-bbox="256 555 1246 730"> <tr> <td>(a) Need for having a radial Magnetic field</td> <td>1</td> </tr> <tr> <td>Achieving the radial field</td> <td>1/2</td> </tr> <tr> <td>(b) Formula</td> <td>1/2</td> </tr> <tr> <td>Calculation of the required resistance</td> <td>1</td> </tr> </table> <p>(a) Need for a radial magnetic field: The relation between the current (i) flowing through the galvanometer coil, and the angular deflection (ϕ) of the coil (from its equilibrium position), is</p> $\phi = \left(\frac{NABl \sin \theta}{k} \right)$ <p>where θ is the angle between the magnetic field \vec{B} and the equivalent magnetic moment $\vec{\mu}_m$ of the current carrying coil.</p> <p>Thus I is not directly proportional to ϕ. We can ensure this proportionality by having $\theta = 90^\circ$. This is possible only when the magnetic field, \vec{B}, is a radial magnetic field. In such a field, the plane of the rotating coil is always parallel to \vec{B}.</p> <p>To get a radial magnetic field, the pole pieces of the magnet, are made concave in shape. Also a soft iron cylinder is used as the core.</p> <p>[Alternatively : Accept if the candidate draws the following diagram to achieve the radial magnetic field.]</p>  <p>(b) We have $R = \left[\frac{V}{I_m} - G \right]$</p> <p>We must also have</p> $\therefore I_m = \frac{V}{R + G}$ $I_m = \frac{\left(\frac{V}{2} \right)}{R' + G}$	(a) Need for having a radial Magnetic field	1	Achieving the radial field	1/2	(b) Formula	1/2	Calculation of the required resistance	1	1/2 1/2 1/2 1/2	
(a) Need for having a radial Magnetic field	1										
Achieving the radial field	1/2										
(b) Formula	1/2										
Calculation of the required resistance	1										



where $R' =$ Resistance required to change the range from) 0 to $V/2$

$$\therefore 1 = \frac{2(R' + G)}{R + G}$$

$$\therefore R' = \frac{R - G}{2}$$

1/2

3

Set1,Q14
Set2,Q22
Set3,Q19

Circuit diagram	1/2
Phasor Diagram	1/2
Obtaining the expression for:	
(i) Impedance	1 1/2
(ii) Phase angle	1/2

The circuit diagram and the phasor diagram, for the given circuit, are as shown.

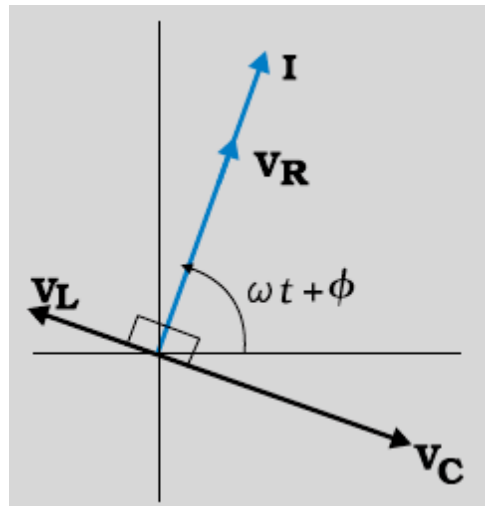
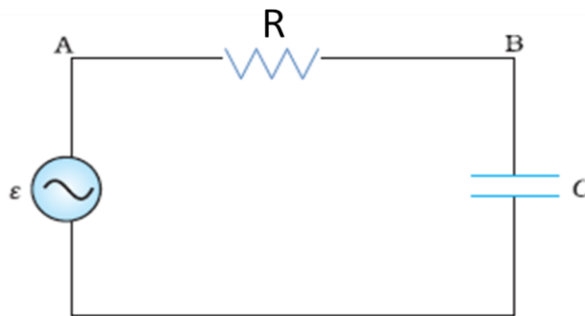

1/2

1/2

Derivation:

The voltage equation, for the circuit, can be written as:

$$v_r + v_c = v$$

The phasor relation, whose vertical component gives the above equation, is

$$\mathbf{V_R} + \mathbf{V_C} = \mathbf{V}$$

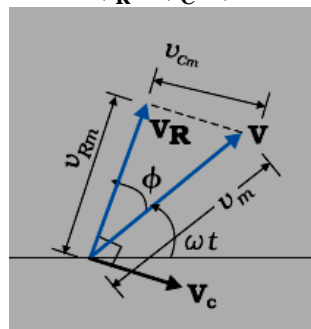

1/2

The Pythagoras theorem gives

	$v_m^2 = v_{RM}^2 + v_{cm}^2$ <p>Substituting the values of v_{RM} and v_{cm}, into this equation, gives</p> $v_m^2 = (i_m R)^2 + (i_m X_C)^2 = i_m^2 (R^2 + X_C^2)$ $\therefore i_m = \frac{v_m}{\sqrt{R^2 + X_C^2}}$ <p>\therefore The impedance of the circuit is given by:</p> $Z = \sqrt{R^2 + X_C^2} = \sqrt{R^2 + \frac{1}{\omega^2 C^2}}$ <p>The phase angle ϕ is the angle between V_R and V. Hence</p> $\tan \phi = \frac{X_C}{R} = \frac{1}{\omega C R}$	<p>1/2</p> <p>1/2</p> <p>1/2</p>	3								
Set1,Q15 Set2,Q11 Set3,Q20	<table border="1" style="width: 100%; border-collapse: collapse;"> <tbody> <tr> <td>(i) Formula for magnetic moment</td> <td style="text-align: right;">1/2</td> </tr> <tr> <td>Calculation of magnetic moment</td> <td style="text-align: right;">1</td> </tr> <tr> <td>(ii) Formula for torque</td> <td style="text-align: right;">1/2</td> </tr> <tr> <td>Calculation of torque</td> <td style="text-align: right;">1</td> </tr> </tbody> </table> <p>(i) Associated magnetic moment</p> $\mu_m = niA$ $= 2000 \times 4 \times 1.6 \times 10^{-4} \text{ A} - \text{m}^2$ $= 1.28 \text{ A} - \text{m}^2$ <p>(ii) torque $= \mu_m B \sin \theta$</p> $= 1.28 \times 7.5 \times 10^{-2} \times \sin 30^\circ$ $= 0.048 \text{ N} - \text{m}$	(i) Formula for magnetic moment	1/2	Calculation of magnetic moment	1	(ii) Formula for torque	1/2	Calculation of torque	1	<p>1/2</p> <p>1/2</p> <p>1/2</p> <p>1/2</p> <p>1/2</p> <p>1/2</p>	3
(i) Formula for magnetic moment	1/2										
Calculation of magnetic moment	1										
(ii) Formula for torque	1/2										
Calculation of torque	1										
Set1,Q16 Set2,Q12 Set3,Q21	<table border="1" style="width: 100%; border-collapse: collapse;"> <tbody> <tr> <td>(a) Formula</td> <td style="text-align: right;">1/2</td> </tr> <tr> <td>Calculation of the ratio</td> <td style="text-align: right;">1</td> </tr> <tr> <td>(b) Answering about Conservation of Energy</td> <td style="text-align: right;">1/2</td> </tr> <tr> <td>Explanation</td> <td style="text-align: right;">1</td> </tr> </tbody> </table> <p>(a) $\frac{I_{max}}{I_{min}} = \left \frac{a_1 + a_2}{a_1 - a_2} \right ^2$</p> <p>Here $\frac{a_1}{a_2} = \sqrt{\frac{w_2}{w_1}} = \sqrt{\frac{4}{1}} = \frac{2}{1}$</p> $\therefore \frac{I_{max}}{I_{min}} = \left \frac{2a_2 + a_2}{2a_2 - a_2} \right ^2 = 9:1$ <p>(b) There is NO violation of the conservation of energy. The appearance of the bright and dark fringes is simply due to a 'redistribution of energy'.</p>	(a) Formula	1/2	Calculation of the ratio	1	(b) Answering about Conservation of Energy	1/2	Explanation	1	<p>1/2</p> <p>1/2</p> <p>1/2</p> <p>1/2</p> <p>1</p>	3
(a) Formula	1/2										
Calculation of the ratio	1										
(b) Answering about Conservation of Energy	1/2										
Explanation	1										
Set1,Q17 Set2,Q13 Set3,Q22	<table border="1" style="width: 100%; border-collapse: collapse;"> <tbody> <tr> <td>(a) Factors by which the resolving power can be increased.</td> <td style="text-align: right;">1</td> </tr> <tr> <td>(b) Formula</td> <td style="text-align: right;">1/2</td> </tr> <tr> <td>Estimation of angular separation</td> <td style="text-align: right;">1 1/2</td> </tr> </tbody> </table> <p>(a) The resolving power of a telescope can be increased by</p>	(a) Factors by which the resolving power can be increased.	1	(b) Formula	1/2	Estimation of angular separation	1 1/2				
(a) Factors by which the resolving power can be increased.	1										
(b) Formula	1/2										
Estimation of angular separation	1 1/2										

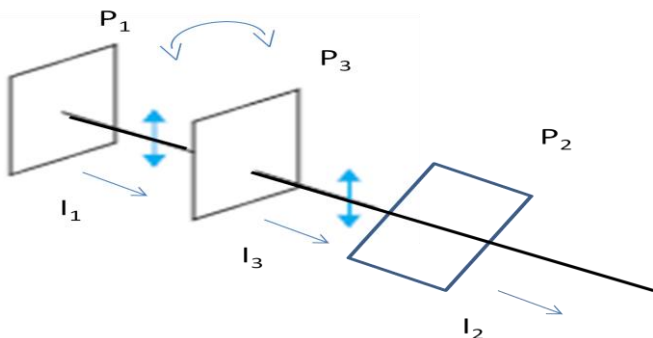

	<p>(i) increasing the diameter of its objective (ii) using light of short wavelength</p> <p>[Note: Give full credit even if a student writes just the first of these two factors.]</p> <p>(b) Position of Maxima: $\theta \approx \left(n + \frac{1}{2}\right) \frac{\lambda}{a}$; position of minima = $\frac{n\lambda}{a}$</p> <p>For first order maxima, $\theta = \frac{3\lambda}{2a}$</p> <p>and for third order minima, $\theta = \frac{3\lambda}{a}$</p> <p>$\therefore$ Required angular separation</p> $= \frac{3\lambda}{2a} = \frac{3 \times 600 \times 10^{-9}}{2 \times 1 \times 10^{-3}} \text{ radian}$ $= 9 \times 10^{-4} \text{ radian}$	<p>1</p> <p>1/2</p> <p>1/2</p> <p>1/2</p> <p>1/2</p>	<p>3</p>						
<p>Set1,Q18 Set2,Q14 Set3,Q11</p>	<table border="1" style="width: 100%; border-collapse: collapse;"> <tbody> <tr> <td style="padding: 5px;">(a) Reason for preferring sun glasses made up of polaroids</td> <td style="text-align: right; padding: 5px;">1</td> </tr> <tr> <td style="padding: 5px;">(b) Formula for intensity of light transmitted through P₂</td> <td style="text-align: right; padding: 5px;">1/2</td> </tr> <tr> <td style="padding: 5px;">Plot of I vs θ</td> <td style="text-align: right; padding: 5px;">1/2</td> </tr> </tbody> </table> <p>(a) Polaroid sunglasses are preferred because they can be much more effective than coloured sunglasses in cutting off the harmful (UV) rays of the sun.</p> <p>[Alternatively : Polaroid sun glasses are preferred over coloured sun glasses because they are more effective in reducing the glare due to reflections from horizontal surfaces.]</p> <p>[Alternatively : Polaroid sun glasses are preferred over coloured sun glasses because they provide a better protection to our eyes.]</p> <p>(b)</p> <div style="text-align: center;">  </div> <p>Let θ be the angle between the pass axis of P₁ and P₃. The angle between the pass axis of P₃ and P₂ would then be $\left(\frac{\pi}{2} - \theta\right)$.</p> <p>By Malus' law,</p> $I_3 = I_1 \cos^2 \theta$ <p>and $I_2 = I_3 \cos^2 \left(\frac{\pi}{2} - \theta\right) = I_3 \sin^2 \theta$</p> $\therefore I_2 = I_1 \cos^2 \theta \sin^2 \theta = \frac{I_1 (\sin 2\theta)^2}{4}$ <p>The plot of I_2 vs θ, therefore, has the form shown below:</p>	(a) Reason for preferring sun glasses made up of polaroids	1	(b) Formula for intensity of light transmitted through P ₂	1/2	Plot of I vs θ	1/2	<p>1</p> <p>1/2</p> <p>1/2</p> <p>1/2</p>	
(a) Reason for preferring sun glasses made up of polaroids	1								
(b) Formula for intensity of light transmitted through P ₂	1/2								
Plot of I vs θ	1/2								

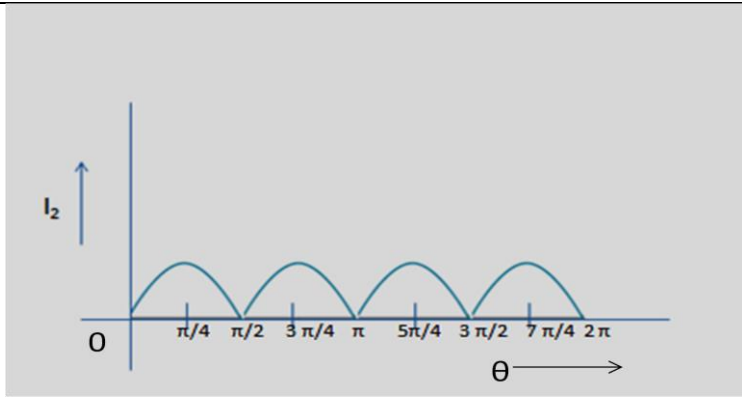
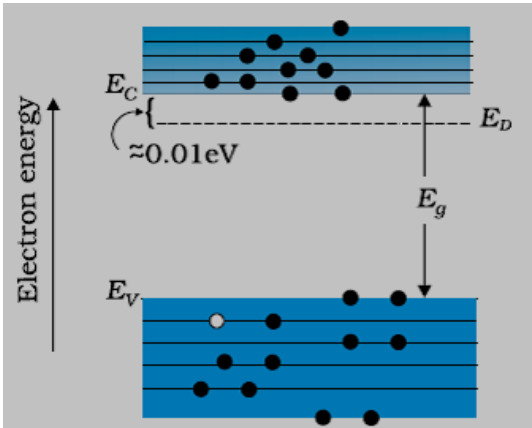
		1/2	3
Set1,Q19 Set2,Q15 Set3,Q12	<div style="border: 1px solid black; padding: 5px;"> <p>(a) Completing the reactions $\frac{1}{2} + \frac{1}{2}$</p> <p>(b) Basic processes involved in β^- and β^+ decay $\frac{1}{2} + \frac{1}{2}$</p> <p>(c) Reason for difficulty in detecting neutrinos 1</p> </div> <p>(a) We have</p> <p>(i) ${}^{208}_{84}\text{Po} \rightarrow {}^{204}_{82}\text{Pb} + {}^4_2\text{He} + Q$ (Also accept if Q is not written)</p> <p>(ii) ${}^{32}_{15}\text{P} \rightarrow {}^{32}_{16}\text{S} + {}^0_{-1}e + \bar{\nu}$ [Also accept if $\bar{\nu}$ is not written]</p> <p>(b) The basic processes involved are</p> <p>(i) ${}^1_0n \rightarrow {}^1_1p + {}^0_{-1}\beta^- + \bar{\nu}$ 1/2</p> <p>(ii) ${}^1_1p \rightarrow {}^1_0n + {}^0_1\beta^+ + \nu$ 1/2</p> <p>(c) Neutrinos are difficult to detect because:</p> <p>(i) they have only weak interactions with other particles</p> <p>(ii) they can penetrate large quantity of matter without any interaction.</p> <p>[Any one] 1</p>	1/2 1/2 1	3
Set1,Q20 Set2,Q16 Set3,Q13	<div style="border: 1px solid black; padding: 5px;"> <p>Energy Band Diagrams $\frac{1}{2} + \frac{1}{2}$</p> <p>Explaining the role of donor and acceptor energy levels 1+1</p> </div>  <p>(i) n-type semiconductor at $T > 0\text{K}$</p>	1/2	



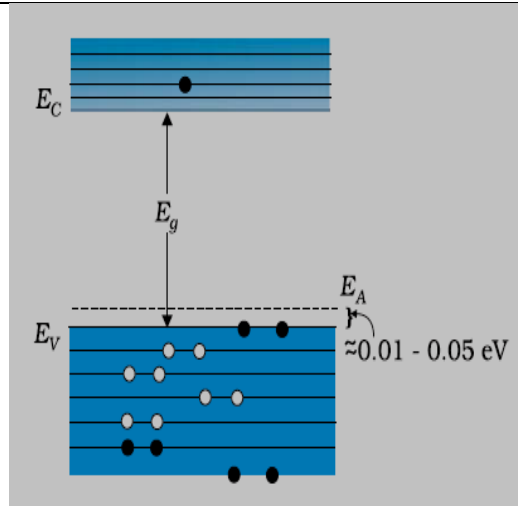

(ii) p-type semiconductor at $T > 0K$

For a n-type semiconductor

The electrons, from the donor impurity atoms, can move into the conduction band with very small supply of energy. The conduction band, therefore, has electrons as the majority charge carriers.

For a p-type semiconductor

In these semiconductors, a very small supply of energy can cause an electron from its valence band to jump to the acceptor energy level. The valence band, therefore, has a dominant density of holes in it. This effectively implies that the holes are the majority charge carriers in a p-type semiconductor.

1/2

1

1

3

Set1,Q21
Set2,Q17
Set3,Q14

Plot of transfer characteristics; use & reason	1/2 + 1/2
Circuit diagram	1
Working	1

The transfer characteristic has the form shown:

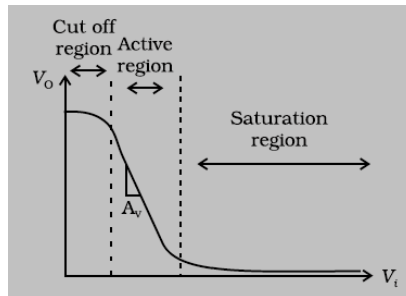

The Active Region of the transfer characteristic is used for amplification because in this region, I_C increases almost linearly with increase of V_i

The circuit diagram of the base biased transistor amplifier, in CE configuration, is shown below:

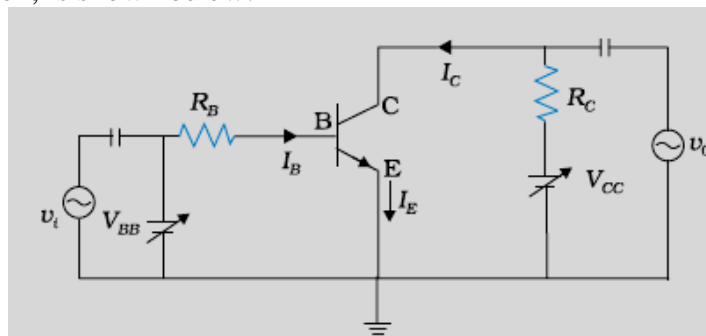

1/2

1/2

1

	<p>Working: The sinusoidal voltage, superposed on the dc base bias, causes the base current to have sinusoidal variations.</p> <p>As a result the collector current, also has similar sinusoidal variations present in it.</p> <p>The output, between the collector and the ground, is an amplified version of the input sinusoidal voltage.</p> <p>(Also accept 'other forms' for explanation of 'working')</p>	1	3										
Set1,Q22 Set2,Q18 Set3,Q15	<table border="1"> <tr> <td>Explanation of each of three terms</td> <td>1+1+1</td> </tr> </table> <p>(i) Internet Surfing Visiting, or using, the different websites on the internet.</p> <p>(ii) Social networking Social networking implies using site like (a) Facebook, Twitter, etc, to share ideas and information with a large number of people. (b) Using internet for chatting, video sharing, etc, among friends and acquaintances.</p> <p>(Any one)</p> <p>(iii) E-mail Using internet (rather than the post office) for exchanging (multimedia) communication between different persons and organizations.</p>	Explanation of each of three terms	1+1+1	1 1 1	3								
Explanation of each of three terms	1+1+1												
Section D													
Set1,Q23 Set2,Q23 Set3,Q23	<table border="1"> <tr> <td>(1) Value displayed by Dr. Kapoor Bimla's parents</td> <td>1+1</td> </tr> <tr> <td>(2) Reason for safety</td> <td>1</td> </tr> <tr> <td>(3) Definition and Significance</td> <td>½ + ½</td> </tr> </table> <p>(1) Dr. Kapoor : Helpful & Considerate Bimla's Parents: Gratefulness</p> <p>(2) It is considered safe to be inside a car during lightening and thunderstorm as the electric field inside a conductor is zero.</p> <p>(3) Dielectric strength of a dielectric indicates the strength of the electric field that a dielectric can withstand without breaking down. This signifies the maximum electric field up to which the dielectric can safely play its role.</p>	(1) Value displayed by Dr. Kapoor Bimla's parents	1+1	(2) Reason for safety	1	(3) Definition and Significance	½ + ½	1 1 1 ½ ½	4				
(1) Value displayed by Dr. Kapoor Bimla's parents	1+1												
(2) Reason for safety	1												
(3) Definition and Significance	½ + ½												
Section E													
Set1,Q24 Set2,Q26 Set3,Q25	<table border="1"> <tr> <td>(a) Statement of Lenz's law</td> <td>1</td> </tr> <tr> <td>Predicting the polarity</td> <td>1</td> </tr> <tr> <td>(b) (i) Formula</td> <td>½</td> </tr> <tr> <td>Substitution and Calculation</td> <td>1½</td> </tr> <tr> <td>(ii) Effect on voltage</td> <td>1</td> </tr> </table> <p>(a) Lenz's law: The polarity of induced emf is such that it tends to produce a current which opposes the change in magnetic flux that produced it.</p>	(a) Statement of Lenz's law	1	Predicting the polarity	1	(b) (i) Formula	½	Substitution and Calculation	1½	(ii) Effect on voltage	1	1	
(a) Statement of Lenz's law	1												
Predicting the polarity	1												
(b) (i) Formula	½												
Substitution and Calculation	1½												
(ii) Effect on voltage	1												

Polarity A → (+ve); B → (-ve)

(b) (i) $V = Blv$

Here B = vertical component of Earth's magnetic field

$$B = (5 \times 10^{-4} \sin 30^\circ) T = 2.5 \times 10^{-4} T$$

$$\therefore V = \left[2.5 \times 10^{-4} \times 25 \times \frac{1800 \times 10^3}{60 \times 60} \right] \text{ volt}$$

$$= 3.125 \text{ volt}$$

(ii) Now B = horizontal component of Earth's magnetic field

$$= B \cos 30^\circ = \frac{B\sqrt{3}}{2}$$

$$\therefore V' = \sqrt{3}V = 1.732 \times 3.125 \text{ volt} \cong 5.4 \text{ volt}$$

OR

Definition of mutual inductance	1
Factors affecting mutual inductance	1
Formulae for the three cases	1/2
Calculations for plotting the graphs	1
Plots of three graphs	1/2 + 1/2 + 1/2

Mutual Inductance:

The mutual inductance, of a pair of coils, equals the magnetic flux linked with one of them due to a unit current in the other.

Alternatively, The mutual inductance, of a pair of coils, equals the emf induced in one of them when the rate of change of current in the other is unity.

Factors affecting the mutual inductance of a pair of coils

- (i) The sizes of the two coils
- (ii) The shape of the two coils
- (iii) the distance of separation between the two coils
- (iv) The nature of the medium between the two coils
- (v) The relative orientation of the two coils.

[NOTE: Any two]

From $t = 0$ to $t = 3\text{s}$ ($= \frac{30 \text{ cm}}{10 \text{ cm/s}}$), the flux through the coil is zero.

From $t = 3\text{s}$ to $t = 5\text{s}$, the flux through the coil increases from 0 to

$$\left[0.1 \times \left(\frac{20}{100} \right)^2 \right] \text{ Wb, ie } 0.004 \text{ Wb.}$$

From $t = 5\text{s}$ to $t = 11\text{s}$, the flux remains constant at the value 0.004 Wb.

From $t = 11\text{s}$ to $t = 13\text{s}$, the flux through the coil remains zero.

(i) The plot of ϕ against t is, therefore, as shown:

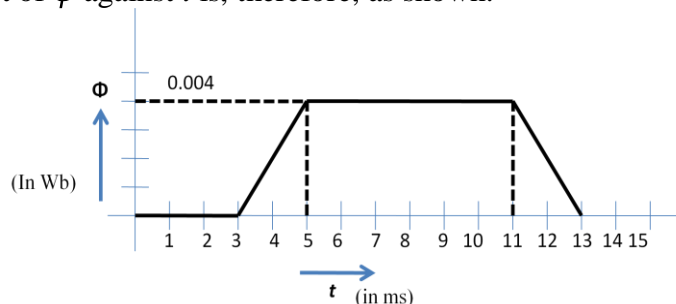

(ii) $\varepsilon = -\frac{d\phi}{dt}$

1/2 + 1/2
1/2
1/2
1/2
1/2
1/2
5

1

1/2 + 1/2

1

The plot of ε against t is, therefore, as shown:

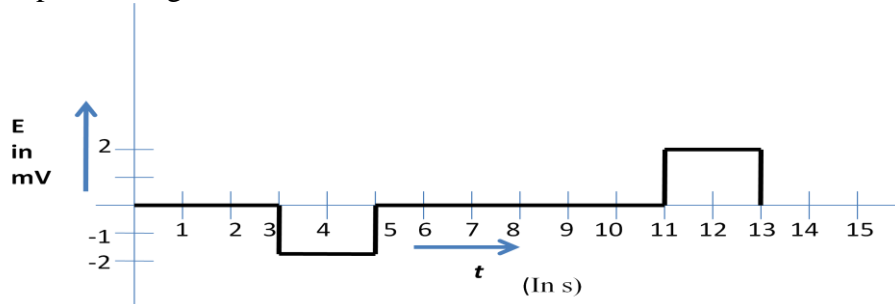

(iii) $i = \frac{\varepsilon}{R} = \frac{2 \times 10^{-3}}{0.1 \Omega} = 20 \text{ mA}$

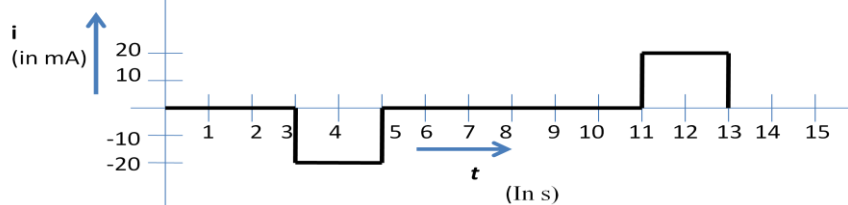

1

1

5

Set1,Q25
Set2,Q24
Set3,Q26

(a) Definition of wavefront	1
Difference from a ray	1
(b) Shape of the wavefront in three cases	1+1+1

(a) A wavefront is defined as a surface of constant phase.

[**Alternatively:** A wavefront is the locus of all points in the medium that have the same phase.]

Difference from a ray:

(i) The ray, at each point of a wavefront, is normal to the wavefront at that point.

(ii) The ray indicates the direction of propagation of wave while the wavefront is the surface of constant phase.

(Any one)

(b) The shape of the wavefront, in the three cases, are as shown.

(i)

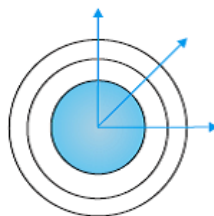

(ii)

1

1

1

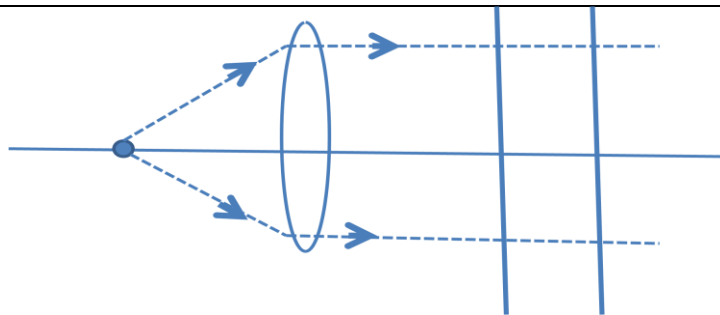

(iii)

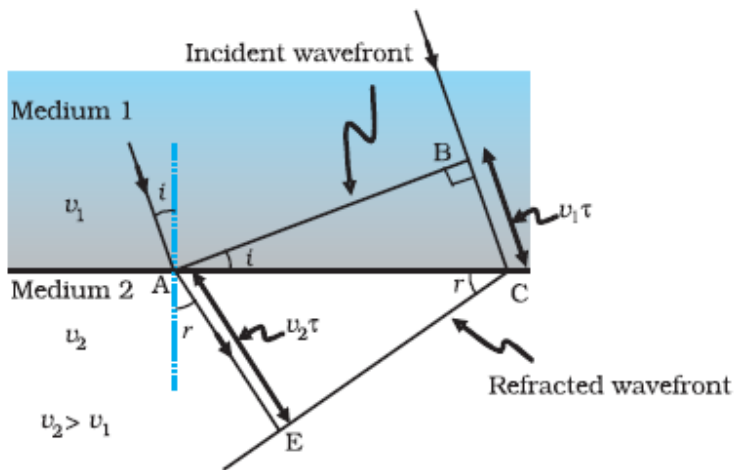

OR

(a) Ray diagram of compound microscope	1
Expression for total magnification	2
(b) Effect on resolving power in cases (i) and (ii)	$\frac{1}{2} + \frac{1}{2}$
Reasons for each case	$\frac{1}{2} + \frac{1}{2}$

(a) The ray diagram, showing image formation by a compound microscope, is given below:

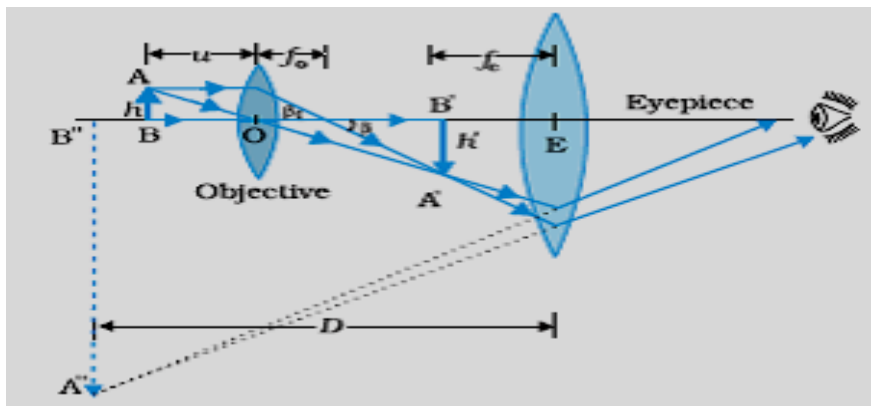

Linear magnification due to the objective = $\frac{h'}{h} = \frac{L}{f_o}$

$$\left(\because \tan \beta = \frac{h}{f_o} = \frac{h'}{L} \right)$$

Here L=tube length=distance between the second focal point of the objective and the first focal point of the eyepiece.

	<p>When the final image is formed at infinity, the angular magnification due to the eye piece equals $\frac{D}{f_e}$. (D=least distance of distinct vision)</p> <p>\therefore Total magnification when the final image is formed at infinity = $\left(\frac{L}{f_o} \cdot \frac{D}{f_e}\right)$</p> <p>(c) (i) Resolving power increases when the focal length of the objective is decreased.</p> <p>(d) This is because the minimum separation, $d_{min} \left(= \frac{1.22 f\lambda}{D}\right)$ decreases when f is decreased.</p> <p>(ii) Resolving power decreases when the wavelength of light is increased. This is because the minimum separation, $d_{min} \left(= \frac{1.22 f\lambda}{d}\right)$ increases when λ is increased.</p>	<p>1/2</p> <p>1/2</p> <p>1/2</p> <p>1/2</p> <p>1/2</p> <p>1/2</p>	<p>5</p>								
<p>Set1,Q26 Set2,Q25 Set3,Q24</p>	<table border="1" data-bbox="242 676 1251 846"> <tr> <td>(a) Writing three features</td> <td>1/2 + 1/2 + 1/2</td> </tr> <tr> <td>Explanation on the basis of Einstein's photoelectric equation</td> <td>1/2 + 1/2 + 1/2</td> </tr> <tr> <td>(b) (i) Reason for equality of the two slopes</td> <td>1</td> </tr> <tr> <td>(ii) Identification of material</td> <td>1</td> </tr> </table> <p>(a) Three features, of photoelectric effect, which cannot be explained by the wave theory of light, are:</p> <p>(i) Maximum kinetic energy of emitted electrons is independent of the intensity of incident light.</p> <p>(ii) There exists a 'threshold frequency' for each photosensitive material.</p> <p>(iii) 'Photoelectric effect' is instantaneous in nature.</p> <p>Einstein's photoelectric equation</p> $K_{max} = h\nu - \phi_o$ <p>[Alternatively: $eV_o = h\nu - \phi_o$] can be used to explain these features as follows.</p> <p>(i) Einstein's equation shows that $K_{max} \propto \nu$. However, K_{max} does not depend on the intensity of light.</p> <p>(ii) Einstein's equation shows that for $\nu < \frac{\phi_o}{h}$, K_{max} becomes negative, i.e., there cannot be any photoemission for $\nu < \nu_o$ ($\nu_o = \frac{\phi_o}{h}$)</p> <p>(iii) The free electrons in the metal, that absorb completely the energy of the incident photons, get emitted instantaneously.</p> <p>(b)</p> <p>(i) Slope of the graph between V_o and ν (from Einstein's equation) equals (h/e). Hence it does not depend on the nature of the material.</p> <p>(ii) Emitted electrons have greater energy for material M_1. This is because $\phi_o (= h\nu_o)$ has a lower value for material M_1.</p> <p style="text-align: center;">OR</p>	(a) Writing three features	1/2 + 1/2 + 1/2	Explanation on the basis of Einstein's photoelectric equation	1/2 + 1/2 + 1/2	(b) (i) Reason for equality of the two slopes	1	(ii) Identification of material	1	<p>1/2</p> <p>1/2</p> <p>1/2</p> <p>1/2</p> <p>1/2</p> <p>1/2</p> <p>1</p> <p>1</p>	<p>5</p>
(a) Writing three features	1/2 + 1/2 + 1/2										
Explanation on the basis of Einstein's photoelectric equation	1/2 + 1/2 + 1/2										
(b) (i) Reason for equality of the two slopes	1										
(ii) Identification of material	1										

(a) Drawing the Trajectory	1
Estimating the size of the nucleus	1
(b) Establishment of wave nature	1
(c) Estimating the ratio of deBroglie wavelengths	2

(a) The trajectory, traced by the α -particles in the Coulomb field of target nucleus, has the form shown below.

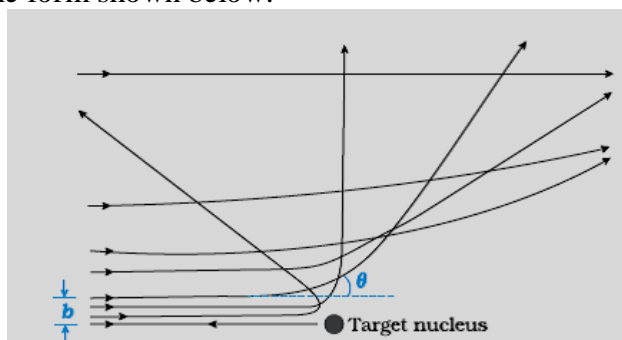

The size of the nucleus was estimated by observing the distance (d) of closest approach, of the α -particles. This distance is given by:

$$\frac{1}{4\pi\epsilon_0} \cdot \frac{(Ze)(2e)}{d} = K$$

where K =kinetic energy of the α -particles when they are far away from the target nuclei.

(b) The wave nature of moving electrons was established through the Davisson-Germer experiment.

In this experiment, it was observed that a beam of electrons, when scattered by a nickel target, showed 'maxima' in certain directions; (like the 'maxima' observed in interference/diffraction experiments with light.)

(c) We have: $\lambda = \frac{h}{p} = \frac{h}{\sqrt{2mqV}}$

$$\therefore \frac{\lambda_d}{\lambda_\alpha} = \sqrt{\frac{m_\alpha q_\alpha}{m_d q_d}}$$

$$= \sqrt{2 \times 2} = 2$$

1

1

1/2

1/2

1/2 + 1/2

1/2

1/2

5